

OpenGL Tutorial

CS 334 Fundamentals of Computer Graphics

<https://learnopengl.com/>

What is OpenGL?

- A rendering library (written in C); API (Application Programming Interface)
- Bindings: C/C++ (official), C#, Python, etc.
- Version: 3.3

```
#version 330 core
```



OpenGL development environment

- Linux, Windows (Visual Studio, a demo project will be posted)
- Libraries: *Freeglut*, *GLEW*, *GLM*

```
#include <glm/glm.hpp>  
#include <GL/glew.h>  
#include <GL/glut.h>
```



- *Freeglut*: OpenGL utility toolkit, creating windows, handling input events
- *GLEW*: OpenGL Extension Wrangler Library, providing extensions
- *GLM*: OpenGL Mathematics

OpenGL development environment (*optional*)

- Visual Studio + *GLFW* + *GLAD* + *ImGui* + *GLM*
- *GLFW*: a library providing simple API for creating windows, contexts and surfaces, receiving input and events
- *GLAD*: a library simplifying the work
- *ImGui*: a graphical user interface (GUI)

```
#include <glad/glad.h> // always put BEFORE GLFW
#include <GLFW/glfw3.h>
#include "imgui.h"
#include "imgui_impl_glfw.h"
#include "imgui_impl_opengl3.h"
```

OpenGL - A large state machine

State machine

- *Context*: the state of OpenGL; defines what it should operate now
- Definition: a collection of context variables

A common workflow:

- Creating an object -> storing reference as as id -> binding it to target location of the context -> unbinding

```
// create object
unsigned int objectId = 0;
glGenObject(1, &objectId);
// bind/assign object to context
glBindObject(GL_WINDOW_TARGET, objectId);
// set options of object currently bound to GL_WINDOW_TARGET
glSetObjectOption(GL_WINDOW_TARGET, GL_OPTION_WINDOW_WIDTH, 800);
glSetObjectOption(GL_WINDOW_TARGET, GL_OPTION_WINDOW_HEIGHT, 600);
// set context target back to default
glBindObject(GL_WINDOW_TARGET, 0);
```

Graphics Pipeline - Overview

3D model coordinates -> 2D colored pixels on screen

Shaders: the steps can easily be executed in parallel

- Definition: tiny programs on GPU
- Replacement: *vertex shader* and *fragment shader*
- *GLSL*: OpenGL Shading Language

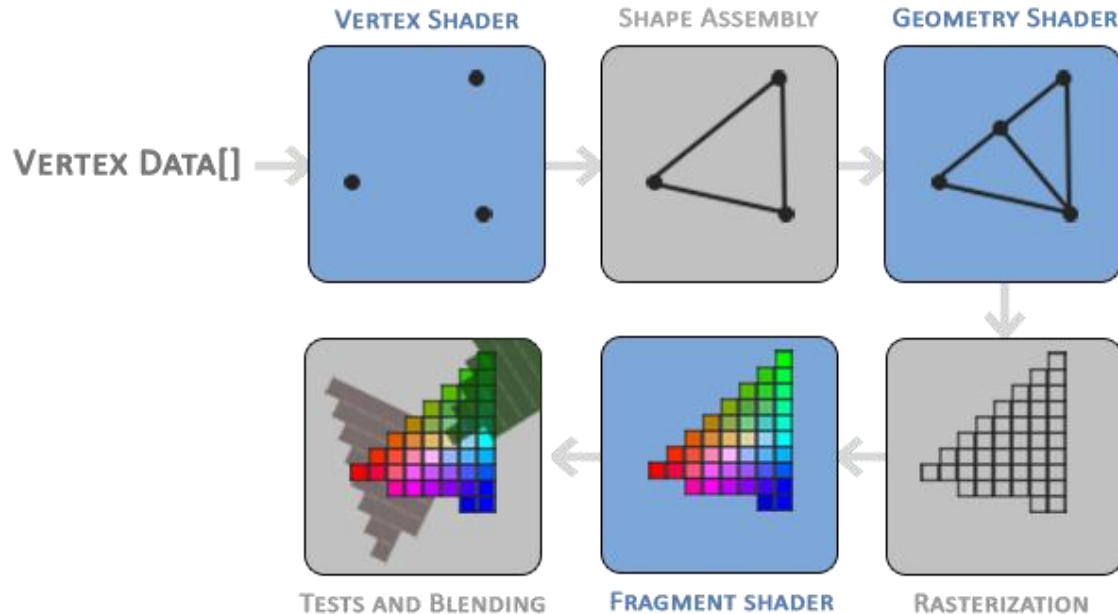

Graphics Pipeline 1 - Vertex data

Vertex data

- A list of 3D coordinates / vertices
- *Attributes*: any data (coordinates, color, etc.) contained in a vertex

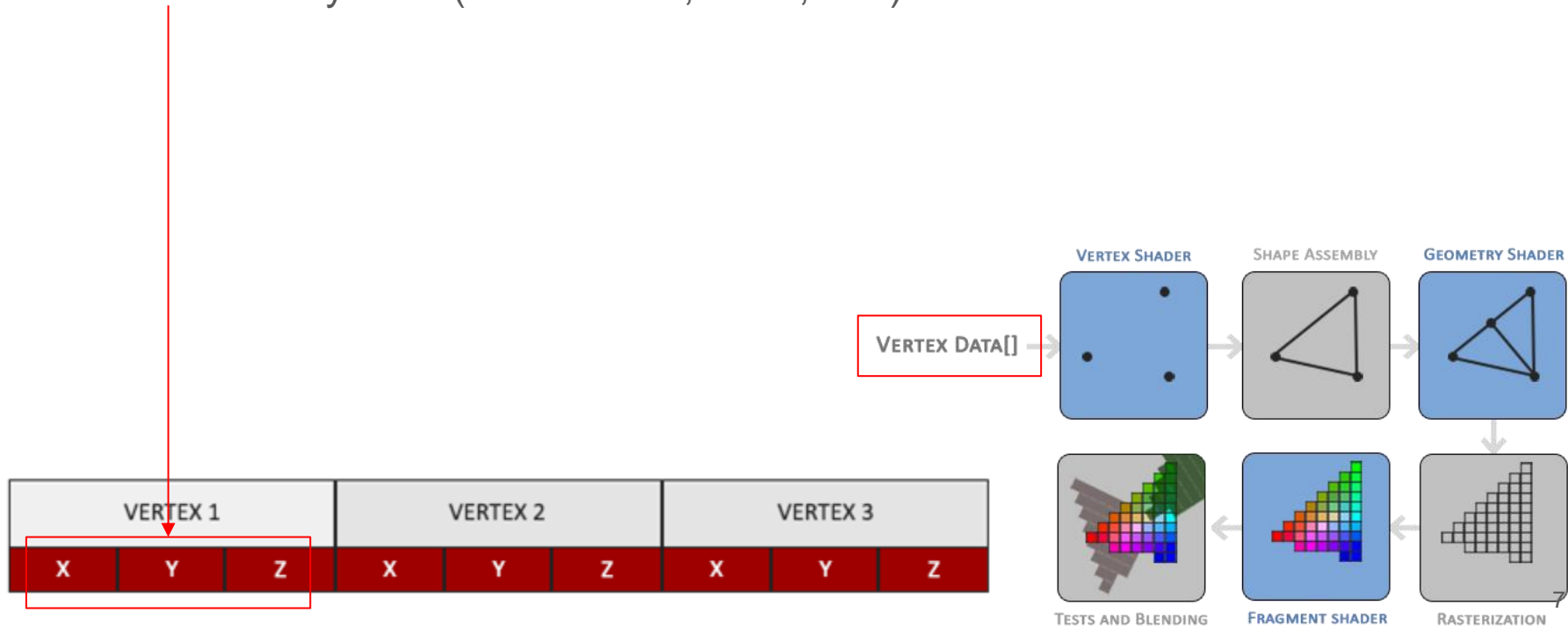

Graphics Pipeline 2 - Vertex shader

Vertex shader (required)

- Input: vertex data
- Transformation on 3D coordinates

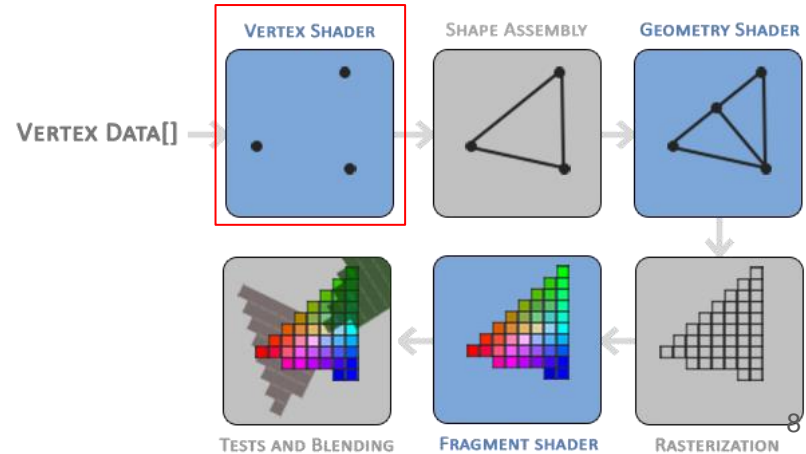

Graphics Pipeline 3 - Shape Assembly

Shape assembly

- Assemble all the points into a specific primitive shape (e.g., triangle, points, etc.)

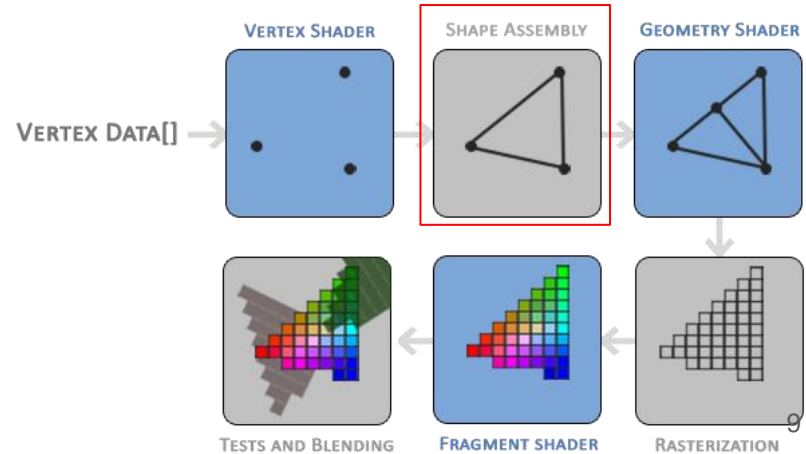

Graphics Pipeline 4 - Geometry shader

Geometry shader

- Generate other shapes / primitives (e.g., insert vertices)
- Will not be used

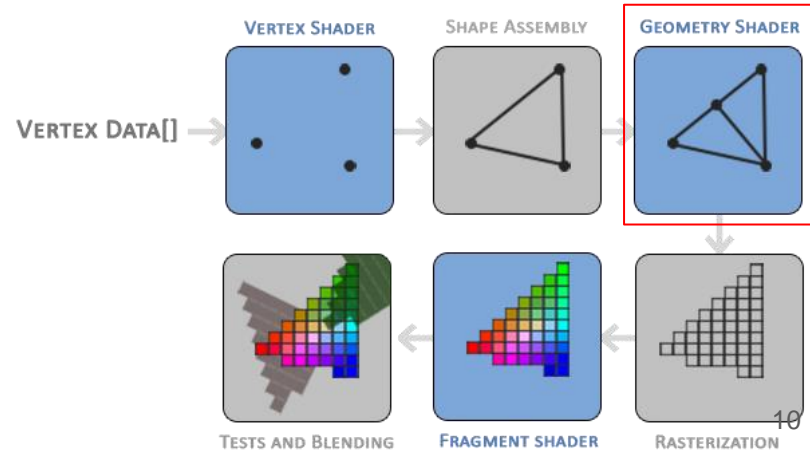

Graphics Pipeline 5 - Rasterization

Rasterization stage

- Map the primitive shapes to pixels on the screen
- Clip the fragments falling outside the view

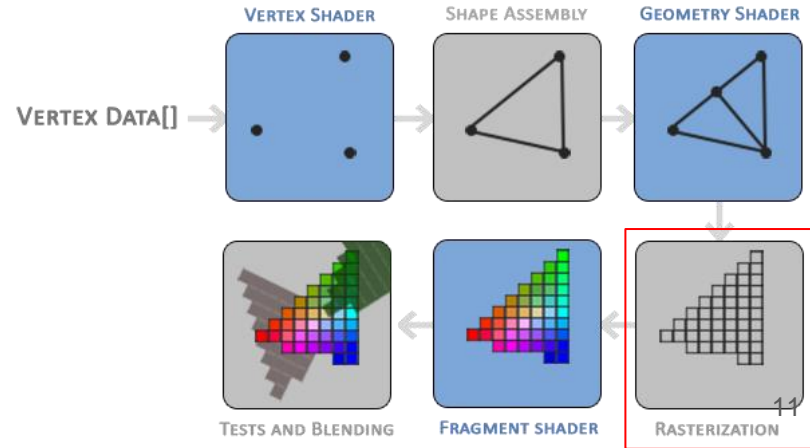

Graphics Pipeline 6 - Fragment Shader

Fragment shader (required)

- Calculate the final color for each pixel
- Apply other high-level effects (illumination, shadow, etc.)

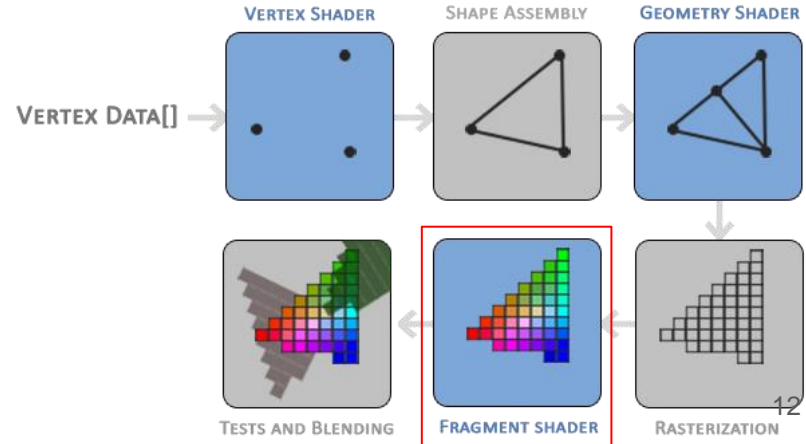

Graphics Pipeline 7 - Tests and Blending

Tests and blending

- Perform depth test and decide the occlusion
- Check opacity and blend the objects

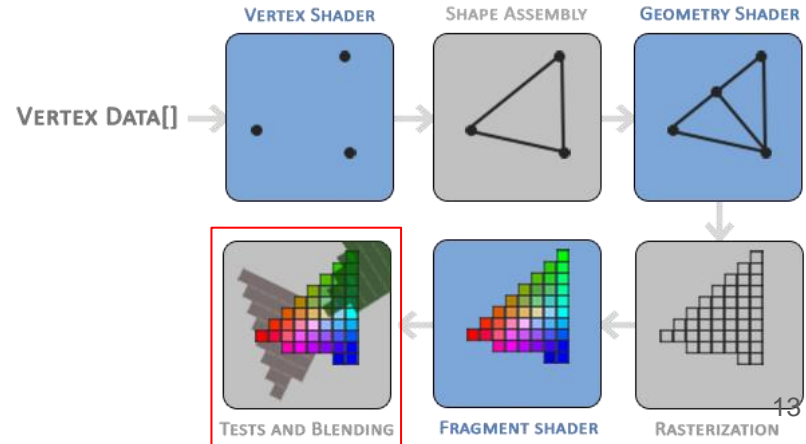

Get started 1 - Vertex Input

Ranges:

- Coordinates range: [-1.0, 1.0]; color range: [0.0, 1.0]

NDC (Normalized Device Coordinates):

- Vertex shader only processes NDC
- Data outside this range will be clipped (*recall...*)

```
float vertices[] = { // attributes
    // positions          // colors
    0.5f, -0.5f, 0.0f,  1.0f, 0.0f, 0.0f, // bottom right
    -0.5f, -0.5f, 0.0f,  0.0f, 1.0f, 0.0f, // bottom left
    0.0f,  0.5f, 0.0f,  0.0f, 0.0f, 1.0f  // top
};
```

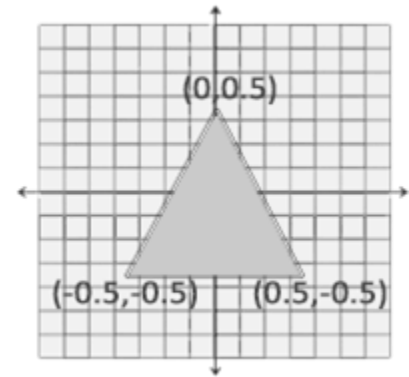

Get started 2 - VBO

Memory management (before drawing):

- Copy the geometry data to GPU (send data all at once)
- Specify the vertex format

VBO: Vertex Buffer Objects

- The memory is managed via VBO which stores vertice data in GPU

Get started 2 - VBO (continue)

How to use VBO: recall the *common workflow*...

```
unsigned int VBO; // generate a unique id
glGenBuffers(1, &VBO); // generate id(s)
glBindBuffer(GL_ARRAY_BUFFER, VBO); // bind the buffer to the target
glBufferData(GL_ARRAY_BUFFER, sizeof(vertices), vertices, GL_STATIC_DRAW);
// copy data into the buffer's memory
// 1st argument: the type of buffer to copy data to
// 2nd argument: specifies the size of data (bytes)
// 3rd argument: actual data to send
// 4th argument: the data is set once and used many times
glBindBuffer(GL_ARRAY_BUFFER, 0); // unbind
```

```
unsigned int VBOs[5]; // generate multiple buffers
glGenBuffers(5, &VBOs);
```

Get started 3 - Vertex Specification

Specify the vertex data by specifying the attributes

- How many attributes
- Size of each attribute
- Where attributes are stored

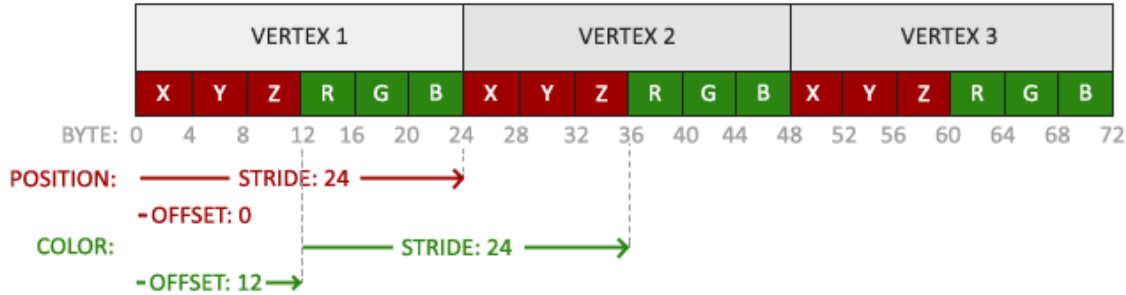

```
// position attribute
glVertexAttribPointer(0, 3, GL_FLOAT, GL_FALSE, 6 * sizeof(float), (void*)0);
glEnableVertexAttribArray(0);
// color attribute
glVertexAttribPointer(1, 3, GL_FLOAT, GL_FALSE, 6 * sizeof(float), (void*)(3 * sizeof(float)));
glEnableVertexAttribArray(1);
```

Get started 3 - Vertex Specification (continue)

How to specify: via *attribute pointers*

```
// position attribute
glVertexAttribPointer(0, 3, GL_FLOAT, GL_FALSE, 6 * sizeof(float), (void*)0);
glEnableVertexAttribArray(0);
// color attribute
glVertexAttribPointer(1, 3, GL_FLOAT, GL_FALSE, 6 * sizeof(float), (void*)(3 * sizeof(float)));
glEnableVertexAttribArray(1);

// 1st argument: location of the attribute
// 2nd argument: number of components
// 3rd argument: data type
// 4th argument: normalize integers (divide by 255 -> 0 or 1)
// 5th argument: stride
// 6th argument: offset

// glEnableVertexAttribArray: enable the attribute giving the location as argument
```

Get started 4 - VAO

Different objects have different vertex formats

VAO (Vertex Array Object):

- Store vertex specifications and which VBO to use
- Allow quickly switching between different vertex formats

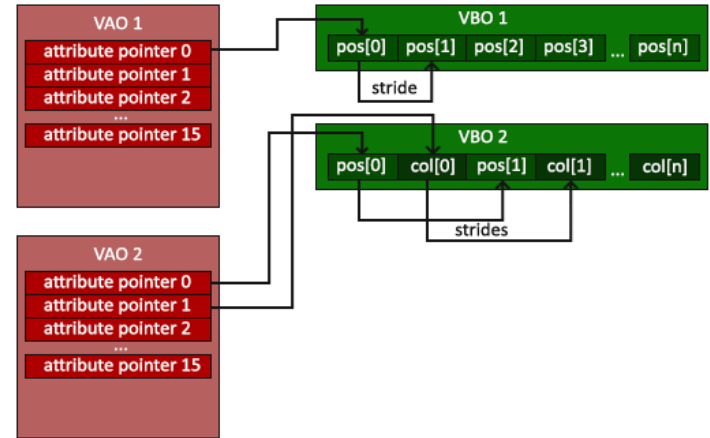

```
unsigned int VBO, VAO;  
glGenVertexArrays(1, &VAO);  
glBindVertexArray(VAO);  
// define VBO and specify vertex attributes using pointers (in previous pages)  
glBindVertexArray(0);
```

Get started 5 - Vertex Shader

A pipeline: vertex data -> vertex shader -> interpolated values -> fragment shader -> output colors

Vertex shader (written in *GLSL*):

- Process each vertex in parallel
- Usually apply transformations: model -> world -> view -> projection (*later*)
- In the end it must write to `gl_Position` built-in variable

Vectors:

- A vector in GLSL has a max size of 4 (`vec.x`, `vec.y`, `vec.z`, `vec.w`)
- `vec.w`: perspective division (*later*)

```
#version 330 core
layout (location = 0) in vec3 aPos; // the first attribute
layout (location = 1) in vec3 aColor; // the second attribute
out vec3 ourColor; // pass the color data to the fragment shader
void main() {
    gl_Position = vec4(aPos, 1.0); // output
    ourColor = aColor;
};
```

Get started 6 - Fragment Shader

Fragment shader (written in *GLSL*):

- Calculate the color of the pixels that are inside the the primitives
- Colors representation: RGBA (red, geen, blue and alpha or opacity) within [0.0, 1.0]
- Calculate lighting, texture, etc.

```
#version 330 core
out vec4 FragColor; // output color
in vec3 ourColor; // vertex color, passed by the vertex shader
void main() {
    FragColor = vec4(ourColor, 1.0f);
}
```

Get started 7 - Shader Compiling

- Store the shader in a constant C string
- Must be compiled and linked at runtime
- Recall the *common workflow...*
- Check if the compilation is successful (see *test0.c*)

```
const char *vertexShaderSource = "#version 330 core\n"
    "layout (location = 0) in vec3 aPos;\n"
    "layout (location = 1) in vec3 aColor;\n"
    "out vec3 ourColor;\n"
    "void main()\n"
    "{\n"
    "    gl_Position = vec4(aPos, 1.0);\n"
    "    ourColor = aColor;\n"
    "}\n0";

unsigned int vertexShader = glCreateShader(GL_VERTEX_SHADER); // referenced by an id
glShaderSource(vertexShader, 1, &vertexShaderSource, NULL); // attach the shader obj
// 1st argument: the object
// 2nd argument: how many strings
glCompileShader(vertexShader);
```

Get started 8 - Shader Linking

Shader program:

- The final linked version of all shaders combined
- Link the outputs of one shader to the inputs of the next shader

```
unsigned int shaderProgram = glCreateProgram(); // referenced by an id
glAttachShader(shaderProgram, vertexShader); // attach the shaders to the program obj
glAttachShader(shaderProgram, fragmentShader);
glLinkProgram(shaderProgram);
// check for linking errors...
glDeleteShader(vertexShader); // once we link the shader objects, they are no longer needed
glDeleteShader(fragmentShader);
glUseProgram(shaderProgram); // activate the program
```

Get started 9 - Summary

The general process:

```
// Initialization code...
// 1. bind VAO
glBindVertexArray(VAO);
// 2. copy our vertices array to VBO
glBindBuffer(GL_ARRAY_BUFFER, VBO);
glBufferData(GL_ARRAY_BUFFER, sizeof(vertices), vertices, GL_STATIC_DRAW);
// 3. set attributes pointers
glVertexAttribPointer(0, 3, GL_FLOAT, GL_FALSE, 3 * sizeof(float), (void*)0);
glEnableVertexAttribArray(0);
// 4. use the shader program (compile and link)
glUseProgram(shaderProgram);
glBindVertexArray(VAO);
// draw objects...
glDrawArrays(GL_TRIANGLES, 0, 3);
// 1st argument: primitive (can also be points, lines)
// 2nd argument: starting index of the vertex array
// 3rd argument: how many vertices to draw
// 5. unbind
```

Advanced features 1 - EBO

Problem: overlap in triangle vertices

EBO (element buffer objects):

- Store indices for deciding which vertices to draw
- Specify the *unique* vertices and the indices to draw

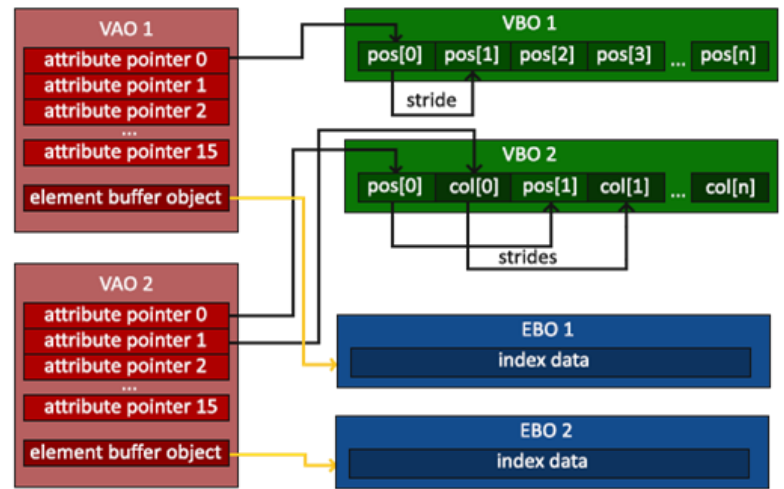

```
float vertices[] = {  
    // first triangle  
    0.5f,  0.5f, 0.0f, // top right  
    0.5f, -0.5f, 0.0f, // bottom right  
    -0.5f, 0.5f, 0.0f, // top left  
    // second triangle  
    0.5f, -0.5f, 0.0f, // bottom right  
    -0.5f, -0.5f, 0.0f, // bottom left  
    -0.5f,  0.5f, 0.0f // top left  
};
```



```
float vertices[] = {  
    0.5f,  0.5f, 0.0f, // top right  
    0.5f, -0.5f, 0.0f, // bottom right  
    -0.5f, -0.5f, 0.0f, // bottom left  
    -0.5f,  0.5f, 0.0f // top left  
};  
unsigned int indices[] = { // note that we  
    start from 0!  
    0, 1, 3, // first triangle  
    1, 2, 3 // second triangle  
};
```

Advanced features 1 - EBO (continue)

- The process is similar to VBO
- Replace `glDrawArrays` by `glDrawElements`

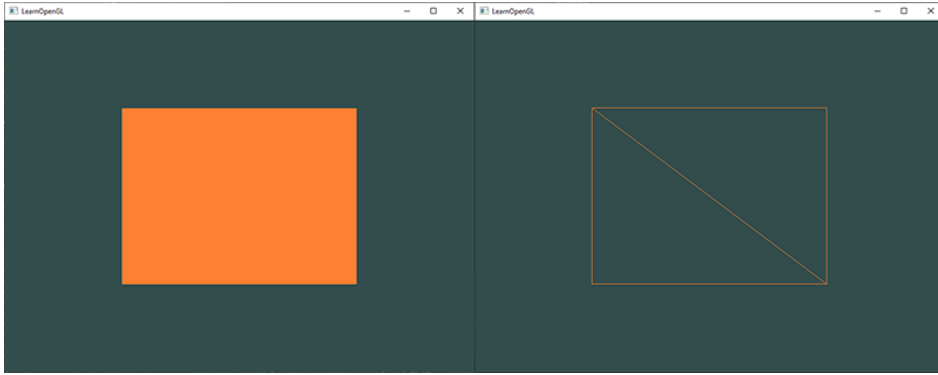

```
unsigned int EBO; // the process is very similar to VBO
glGenBuffers(1, &EBO);
glBindBuffer(GL_ELEMENT_ARRAY_BUFFER, EBO); // bind
glBufferData(GL_ELEMENT_ARRAY_BUFFER, sizeof(indices), indices, GL_STATIC_DRAW); // copy
the data to the buffer
glBindBuffer(GL_ELEMENT_ARRAY_BUFFER, EBO);
glDrawElements(GL_TRIANGLES, 6, GL_UNSIGNED_INT, 0); // take indices from EBO
// 2nd argument: number of elements to draw
// 4th argument: offset
```

Transformation 1 - definition

- In OpenGL, transformations are handled using matrices (4 * 4)
- Vertices in OpenGL can be represented as vectors (4 * 1)

$$\begin{bmatrix} 1 & 0 & 0 & 0 \\ 0 & 1 & 0 & 0 \\ 0 & 0 & 1 & 0 \\ 0 & 0 & 0 & 1 \end{bmatrix} \mathbf{v} = \begin{bmatrix} x \\ y \\ z \\ 1 \end{bmatrix} \quad \text{identity matrix and a vector } \mathbf{v} \text{ (} w=1, \text{ explained later)}$$

```
glm::vec4 Position = glm::vec4(glm::vec3(0.0), 1.0);  
glm::mat4 Model = glm::mat4(1.0);
```

Transformation 2 - scaling

- Defined by 3 scaling variables (for x, y, z), *uniform* if they are the same else *non-uniform*
- Define the scaling matrix on any vector as:

$$\begin{bmatrix} S_1 & 0 & 0 & 0 \\ 0 & S_2 & 0 & 0 \\ 0 & 0 & S_3 & 0 \\ 0 & 0 & 0 & 1 \end{bmatrix} * \begin{bmatrix} x \\ y \\ z \\ 1 \end{bmatrix} = \begin{bmatrix} S_1 * x \\ S_2 * y \\ S_3 * z \\ 1 \end{bmatrix}$$

Transformation 3 - translation

- Add another vector to the original
- Defined in the last column
- This can *NOT* be done using a 3 * 3 matrix

$$\begin{bmatrix} 1 & 0 & 0 & T_1 \\ 0 & 1 & 0 & T_2 \\ 0 & 0 & 1 & T_3 \\ 0 & 0 & 0 & 1 \end{bmatrix} * \begin{bmatrix} x \\ y \\ z \\ 1 \end{bmatrix} = \begin{bmatrix} x + T_1 \\ y + T_2 \\ z + T_3 \\ 1 \end{bmatrix}$$

Transformation 4 - rotation (continue)

- Rotation along x, y, z axis:

$$\begin{bmatrix} 1 & 0 & 0 & 0 \\ 0 & \cos\theta & -\sin\theta & 0 \\ 0 & \sin\theta & \cos\theta & 0 \\ 0 & 0 & 0 & 1 \end{bmatrix} * \begin{bmatrix} x \\ y \\ z \\ 1 \end{bmatrix} \quad \text{X axis}$$

$$\begin{bmatrix} \cos\theta & 0 & \sin\theta & 0 \\ 0 & 1 & 0 & 0 \\ -\sin\theta & 0 & \cos\theta & 0 \\ 0 & 0 & 0 & 1 \end{bmatrix} * \begin{bmatrix} x \\ y \\ z \\ 1 \end{bmatrix} \quad \text{Y axis}$$

$$\begin{bmatrix} \cos\theta & -\sin\theta & 0 & 0 \\ \sin\theta & \cos\theta & 0 & 0 \\ 0 & 0 & 1 & 0 \\ 0 & 0 & 0 & 1 \end{bmatrix} * \begin{bmatrix} x \\ y \\ z \\ 1 \end{bmatrix} \quad \text{Z axis}$$

Transformation 5 - combination

- The power of 4 * 4 matrix: combine scaling / rotation with translation
- Orders are important: read the matrices from right to left
- Suggestion: scaling -> rotation -> translation

$$\begin{bmatrix} sx + t_x \\ sy + t_y \\ sz + t_z \\ 1 \end{bmatrix} = \begin{bmatrix} 1 & 0 & 0 & t_x \\ 0 & 1 & 0 & t_y \\ 0 & 0 & 1 & t_z \\ 0 & 0 & 0 & 1 \end{bmatrix} * \begin{bmatrix} s & 0 & 0 & 0 \\ 0 & s & 0 & 0 \\ 0 & 0 & s & 0 \\ 0 & 0 & 0 & 1 \end{bmatrix} * \begin{bmatrix} x \\ y \\ z \\ 1 \end{bmatrix}$$

Transformation 7 - GLM

```
glm::mat4 trans = glm::mat4(1.0f); // transformation matrix
trans = glm::rotate(trans, glm::radians(90.0f), glm::vec3(0.0, 0.0, 1.0)); // around Z axis
trans = glm::scale(trans, glm::vec3(0.5, 0.5, 0.5));

unsigned int transformLoc = glGetUniformLocation(ourShader.ID, "transform"); // pass the
"uniform" variable to the shader
glUniformMatrix4fv(transformLoc, 1, GL_FALSE, glm::value_ptr(trans));
// 1st argument: location of the "uniform"
// 2nd argument: how many matrices to send
// 3rd argument: whether transpose it
```

In shader:

```
layout (location = 0) in vec3 aPos;
uniform mat4 transform; // receive the uniform

void main() {
    gl_Position = transform * vec4(aPos, 1.0f);
}
```

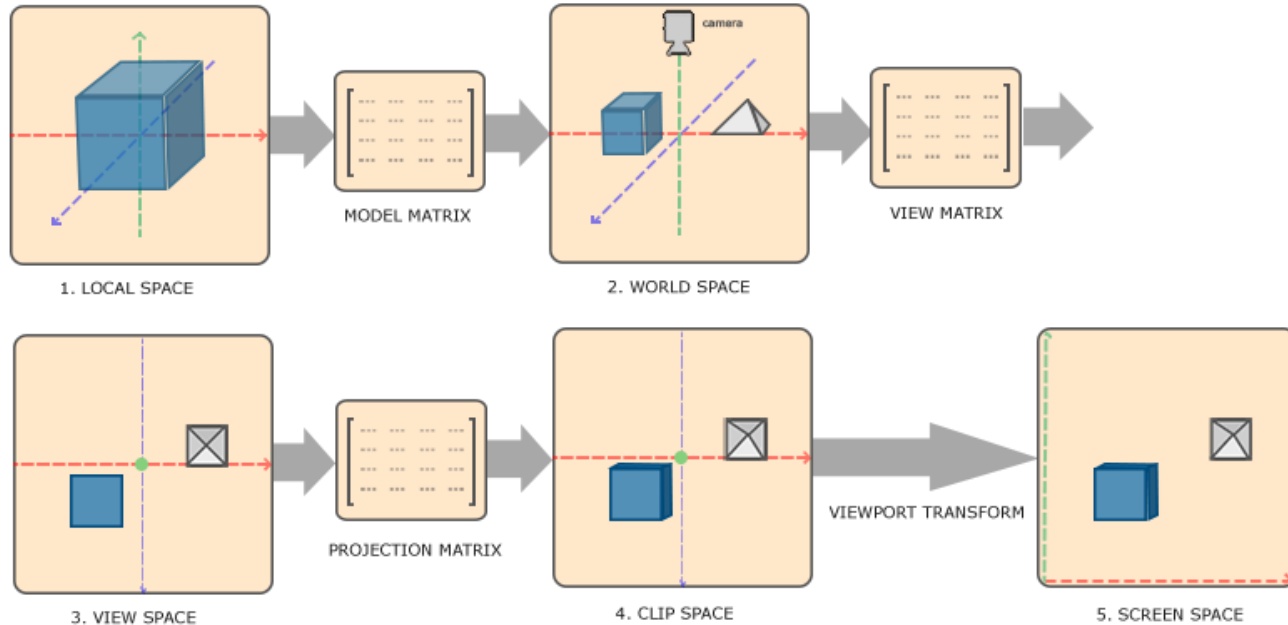

Transformation 8 - coordinate systems (covered later)

- Model space: local to an object
- World space: objects placed relative to each other
- View space: origin at the camera's focal point
- Clip space: the volume the camera sees (near - large, far - small) (a *frustum*)
- Screen space: in pixels

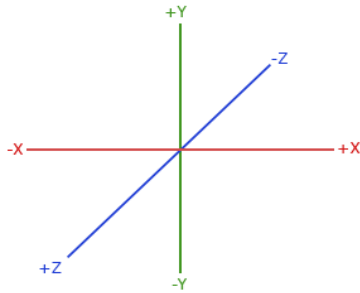

Transformation 8 - coordinate systems (covered later)

- Model space: local to an object
- World space: objects placed relative to each other
- **View space**: origin at the camera's focal point
- **Clip space**: the volume the camera sees (perspective: near - large, far - small) (a *frustum*)
- Screen space: in pixels



view space

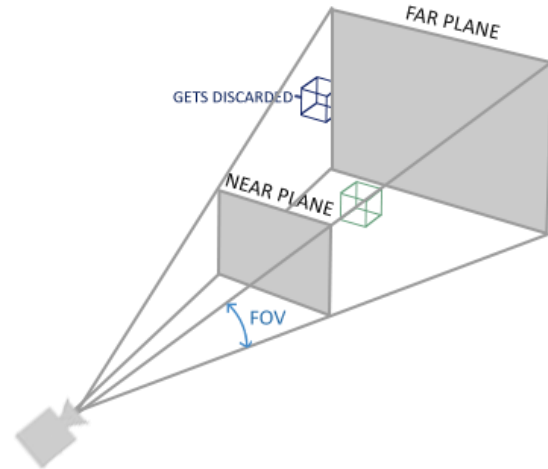

clip space

Transformation 8 - coordinate systems (covered later)

Combination: $V_{clip} = M_{proj} * M_{view} * M_{model} * M_{local}$

Freeglut Quick Start 1 - window

Initialize with a window

```
void initGLUT(int* argc, char** argv) {
    glutInit(&argc, argv);
    glutInitDisplayMode(GLUT_SINGLE | GLUT_RGB); // a single-buffered window
    glutInitWindowSize(SCR_WIDTH, SCR_HEIGHT); // set window size
    glutCreateWindow("example window");
    glutDisplayFunc(display); // set a callback function

    // set menu...
    // set callbacks...
}

void display (void)
{
    glClear(GL_COLOR_BUFFER_BIT); // clear window
    glDrawArrays(GL_TRIANGLES, 0, 3);
    glFlush(); // force execution of GL commands
    glutSwapBuffers(); // swap buffers if the window is double-buffered
}
```

Freeglut Quick Start 2 - callbacks

Put callback functions into the initialization

Note: put global declarations at the beginning of the source file

```
// declarations of callback functions
void display();
void keyRelease(unsigned char key, int x, int y);
void mouseBtn(int button, int state, int x, int y);
void mouseMove(int x, int y);

void initGLUT(int* argc, char** argv) {
    // init...
    // set menu...
    // set callbacks
    glutDisplayFunc(display);
    glutKeyboardUpFunc(keyRelease);
    glutMouseFunc(mouseBtn);
    glutMotionFunc(mouseMove);
}
```

Freeglut Quick Start 2 - callbacks - keypress

```
void keyRelease(unsigned char key, int x, int y) {  
    switch (key) {  
        case 27: // Escape key  
            menu(MENU_EXIT);  
            break;  
    }  
}
```

Freeglut Quick Start 2 - callbacks - mouse move

```
void mouseMove(int x, int y) { // x, y: mouse location in window relative coordinates
    ...
    glutPostRedisplay(); // update the window (redisplay)
}
```

Freeglut Quick Start 3 - menu

```
void menu(int cmd) {
    switch (cmd) {
        case MENU_VIEWMODE:
            ...
            glutPostRedisplay(); // redraw the screen
            break;

        case MENU_EXIT:
            glutLeaveMainLoop();
            break;
    }
}

void initGLUT(int* argc, char** argv) {
    // Create a menu
    glutCreateMenu(menu);
    glutAddMenuEntry("Toggle view mode", MENU_VIEWMODE);
    glutAddMenuEntry("Exit", MENU_EXIT);
    glutAttachMenu(GLUT_RIGHT_BUTTON); // bind to the right button of the mouse
}
```